

ZONE	DESCRIPTION	DRAWN	APPR.	DATE	REV.	CHANGE ORD.
000				06/07/2020	-03	ECO

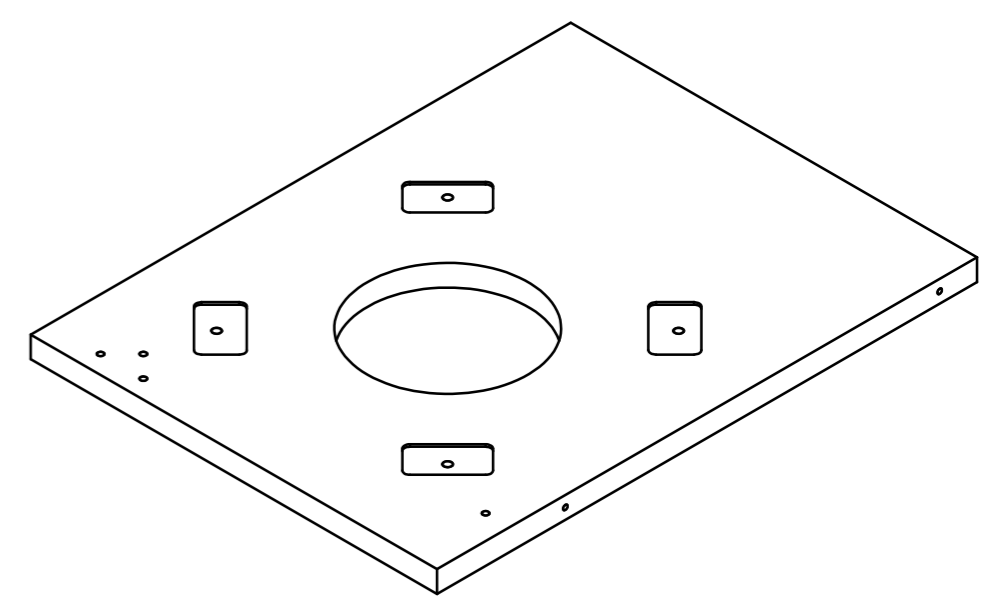
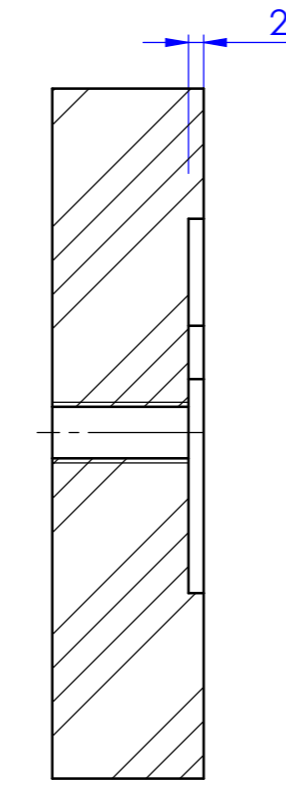
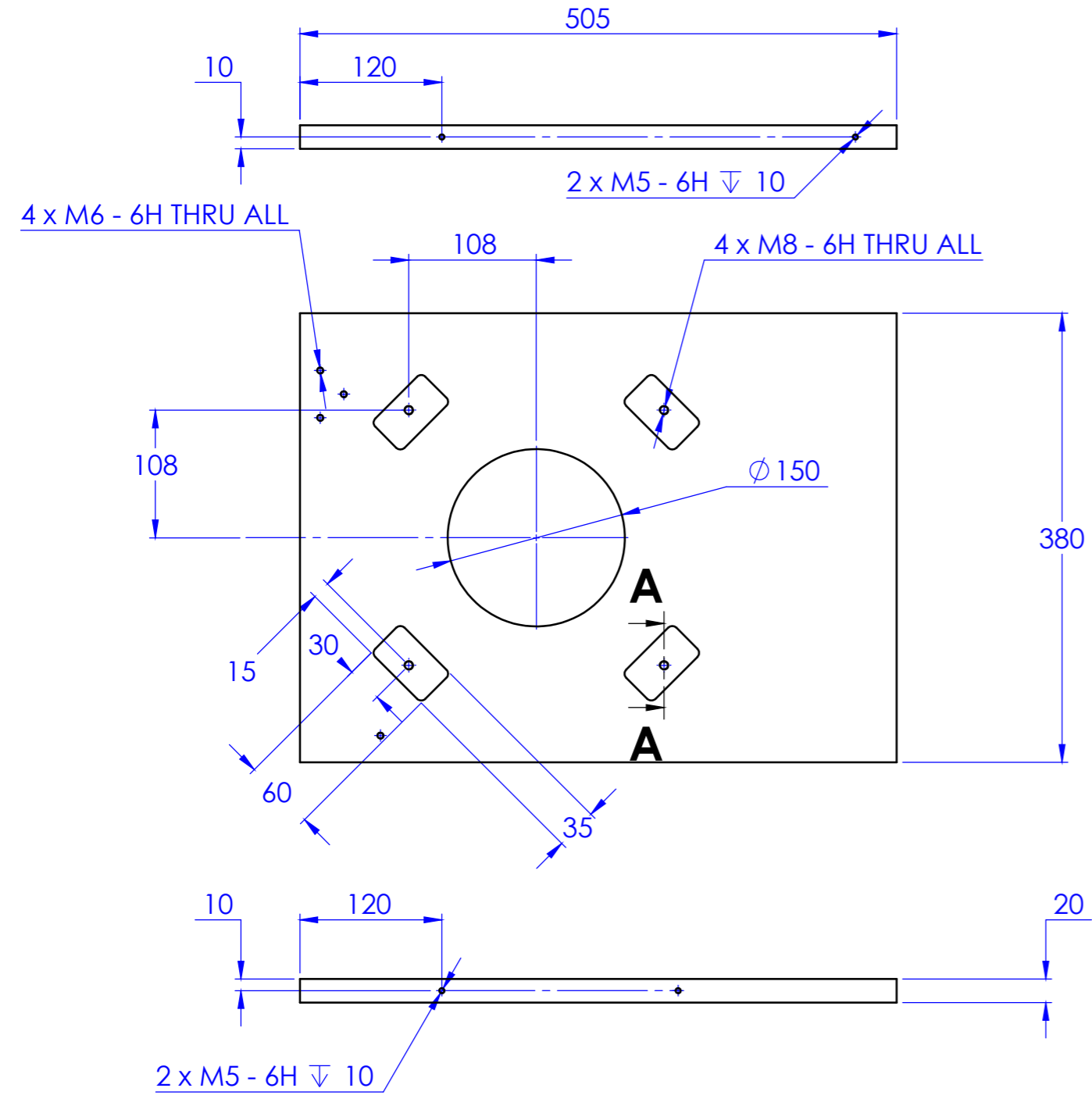

- NOTES:**
- MATERIAL: EN-10025 S235JR**
 - REMOVE ALL BURRS AND SHARP EDGES 0.2 x 45°**
 - MISSING DIMENSION ARE ACCORDING TO 3D CAD FILE**
 - SURFACE FINISH:** ∇_{N8}
 - FINISH: NONE**

DESIGN	NAME	DATE	FINISH: SEE NOTES	ASSEMBLY NAME:	
DRAWN	GUY M.	06/07/2020		SURFACE FINISH: SEE NOTES	NAME: ROBOT BASE
CHECK	YONI (7550)	06/07/2020	SCALE 1:5		DRAWING No. AP1203200
APPR.	CHEN (7699)	06/07/2020		SIZE A3	CAT. R
DIMENSIONS: mm			GENERAL TOLERANCE: 0-200 : ±0.1 200-500 : ±0.2 500-1000 : ±0.3 1000+ : ±0.5		REV. -03
MATERIAL: SEE NOTES				WEIGHT: 27.01Kg	SHEET 1 OF 1
PATH:			DOC.NO. AT0432000 REV.A		